

THIS DRAWING IS UNPUBLISHED. RELEASED FOR PUBLICATION  
 © COPYRIGHT BY TYCO ELECTRONICS CORPORATION. ALL INTERNATIONAL RIGHTS RESERVED.

LOC		DIST		REVISIONS					
AJ		16		P	LTR	DESCRIPTION	DATE	DWN	APVD
				K		REV PER ECO 08-023708	10/17/2008	DW	FB

1. USE INSTRUCTION SHEET 1799-2

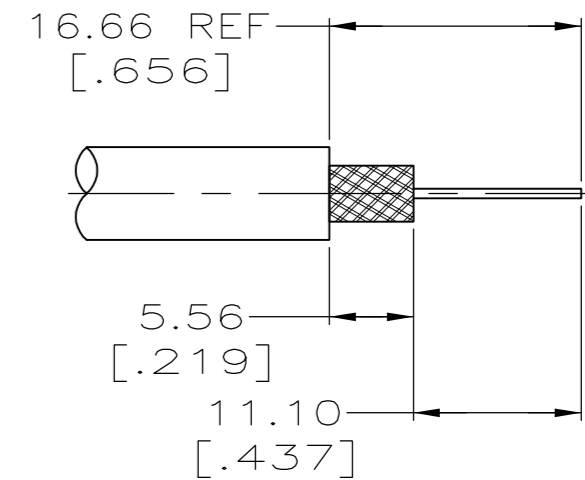
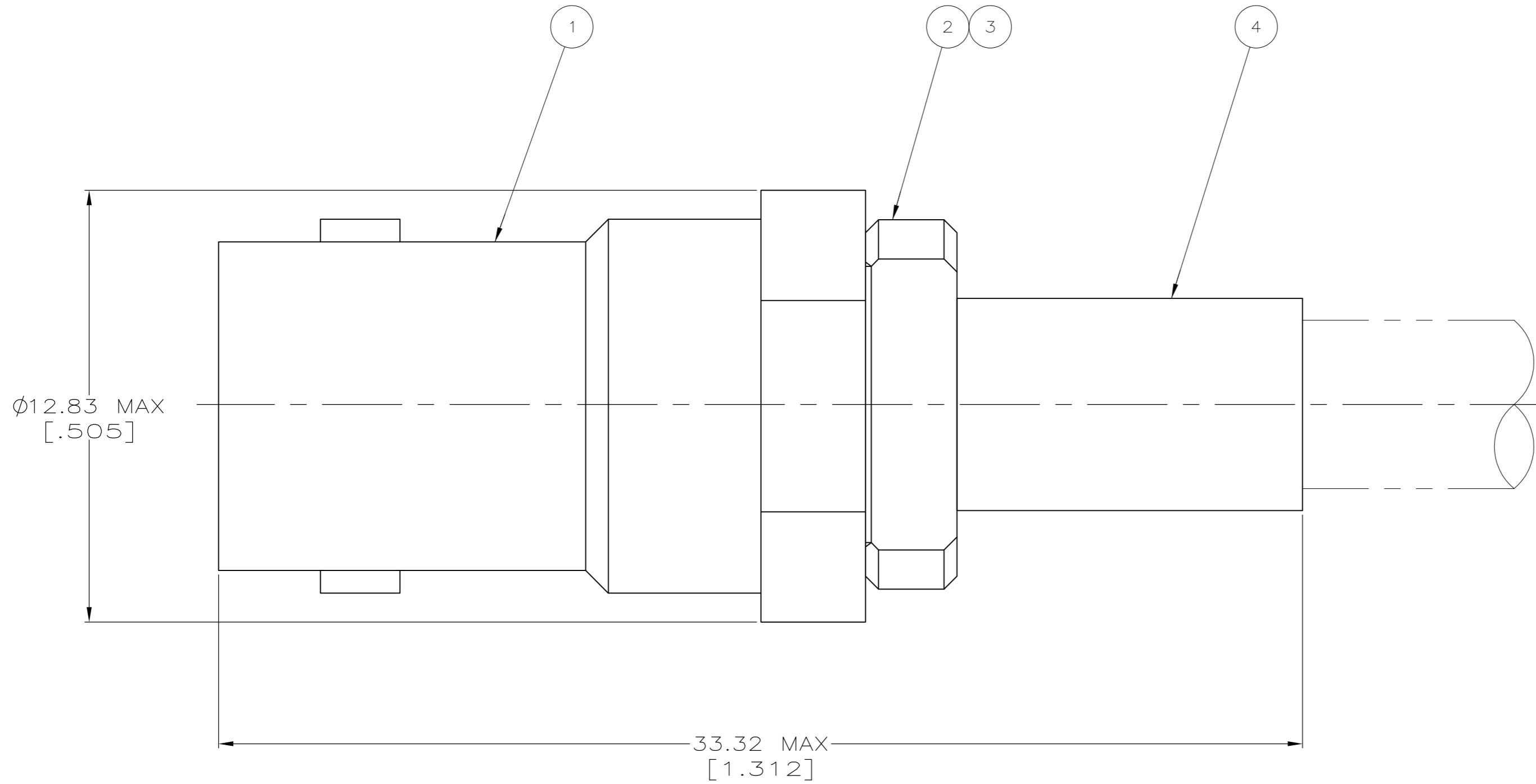

RECOMMENDED STRIP LENGTH  
SCALE 2:1

OBSOLETE	RG-141 & 141A	69331-1	330478	50793-1	2-329106-1	329802	2-329452-3
	RG-142/U, 142A/U, AND 142B/U	69331-1	329099	50793-1	2-329106-1	329802	2-329452-2
SUPERSEDED BY 2-329545-1	RG-58/U, 58A/U, 58B/U, AND 58C/U	69140-1	328663	50793-1	2-329106-1	329802	2-329452-1
SUPERSEDED BY 2-329452-1	RG-58/U, 58A/U, 58B/U, AND 58C/U	69140-1	328663	50793-1	2-329106-1	329802	329452
	FOR USE WITH	CRIMP TOOL	④ FERRULE QTY=1	③ CRIMP END ASSEMBLY QTY=1	② GASKET QTY=1	① JACK ASSEMBLY QTY=1	PART NUMBER

THIS DRAWING IS A CONTROLLED DOCUMENT.		Finish		Material		Part Number	
DWN 14FEB96 MICHAEL E. COWHER		15FEB96		Tyco Electronics Corporation Harrisburg, PA 17105-3608		NAME JACK, BNC	
CHK 15FEB96 FRANK P. MORANA		15FEB96		APVD 15FEB96 FRANK P. MORANA		SIZE A2	
APVD 15FEB96 FRANK P. MORANA		PRODUCT SPEC		APPLICATION SPEC		CAGE CODE 00779	
MATERIAL		FINISH		WEIGHT		DRAWING NO C=329452	
-		-		-		RESTRICTED TO -	
CUSTOMER DRAWING				SCALE 8:1		SHEET 1 OF 1	
						REV K	

3294529452