

LT3795

110V LED Controller with Spread Spectrum Frequency Modulation

DESCRIPTION

Demonstration Circuit 1827A features a 110V LED controller with spread spectrum frequency modulation - the [LT[®]3795](#). Unlike most boosts, the circuit disconnects the output to protect against shorts or other fault conditions when the input voltage exceeds the output. The input voltage range for normal operation is from 8V to 60V. OVLO becomes active for inputs above 63V and the maximum input voltage is 110V. The LED current is 400mA and the switching frequency is 250kHz. The efficiency is 92% when the input is 12V and the LED voltage is at 87V which is the maximum LED voltage.

Spread spectrum switching is available to simplify conducted emissions compliance. There is a 6.8nF capacitor from the RAMP pin to ground to set the rate at which frequency modulation occurs, but resistor R20 shorting the RAMP pin capacitor must be removed to activate spread spectrum.

OVLO and EN/UVLO are both set using resistor dividers. EN/UVLO is set so the circuit will UVLO when the input voltage falls below 6V and will turn on when the input voltage rises above 7.5V.

Current sense resistors program LED current and input regulation current and also determine the monitoring voltages that indicate output and input current. The LED current is set by RS2. ISMON provides a 2.5V/1A voltage that is used to monitor the LED current. Input current regulation occurs at 4A and is set by RS3. IVINCOMP provides a 300mV/1A voltage that is used to monitor the input current. Capacitor C11 on the IVINCOMP pin provides compensation for the input current regulation loop. CTRL1 and CTRL2 are analog dimming inputs that allow external voltages to reduce the LED current from the programmed maximum. CTRL1 and CTRL2 are pulled up to the V_{REF} pin by 100k resistors. SHORTLED and OPENLED are open-collector status flag outputs that are pulled up to the INTV_{CC} pin voltage.

The circuit requires application of an external voltage to the PWM terminal for operation. The external voltage can be a DC level or an appropriate pwm dimming signal. A

common frequency for PWM dimming is 100Hz. The high-side PMOS FET that is used for pwm dimming also disconnects the output to protect against shorts.

The soft-start pin (SS) is configured so the circuit will hiccup when a fault occurs and will not latch off. The demo circuit also supports the adjustment capability of the LT3795 for switching frequency and feedback loop compensation.

The FB pin is programmed using a resistor divider to limit the output voltage in case there is no LED string on the output. When an open LED transient occurs either at start up or because the LED string opens, the peak output voltage may overshoot to 100V but FB will regulate the settled output voltage to 95V.

The demo circuit uses ceramic input and output capacitors. An aluminum electrolytic capacitor can be easily added to the input if it is necessary for stability during conducted emissions testing. The 120V switching MOSFET allows 110V on the input. FB programming inhibits switching at high output voltages so the 100V rating of the rectifier is not exceeded.

The demo circuit is designed to be easily reconfigured to buck mode, buck-boost mode and SEPIC topologies. There are example schematics in the data sheet. Consult the factory for assistance.

Maximum input and output voltages of 110V, spread spectrum switching, fault protection and full monitoring make the LT3795 attractive for high voltage and high power LED circuits, battery chargers and voltage regulators that require an accurate current limit. DC1827A uses the LT3795EFE which is packaged in a thermally enhanced 28-lead TSSOP. The LT3795 data sheet must be read in conjunction with this demo manual to properly use or modify DC1827A.

Design files for this circuit board are available at <http://www.linear.com/demo/DC1827A>

All registered trademarks and trademarks are the property of their respective owners.

PERFORMANCE SUMMARY Specifications are at $T_A = 25^\circ\text{C}$

PARAMETER	CONDITIONS	MIN	TYP	MAX	UNITS
Minimum Input, V_{PVIN}	$V_{LED} = 87\text{V}, I_{LED} \leq 400\text{mA}$			8	V
Maximum Input – Switching, V_{PVIN}	$V_{LED} = 87\text{V}, I_{LED} \leq 400\text{mA}$	60			V
Maximum Input – Not Switching, V_{PVIN}	$V_{OVLO} \geq 1.25\text{V}$	110			V
Maximum LED Voltage, V_{LED}		87			V
LED Current, I_{LED}	$RS2 = 0.62\Omega$		400		mA
Input EN Voltage, $V_{PVIN(EN)}$	V_{PVIN} Rising $R1 = 499\text{k}, R2 = 115\text{k}, R3 = 12.4\text{k}$		7.5		V
Input UVLO Voltage, $V_{PVIN(UVLO)}$	V_{PVIN} Falling $R1 = 499\text{k}, R2 = 115\text{k}, R3 = 12.4\text{k}$		6		V
Input OVLO Turn-Off Voltage, $V_{PVIN(OVLO_TURN-OFF)}$	V_{PVIN} Rising $R1 = 499\text{k}, R2 = 115\text{k}, R3 = 12.4\text{k}$		63.1		V
Input OVLO Turn-On Voltage, $V_{PVIN(OVLO_TURN-ON)}$	V_{PVIN} Falling $R1 = 499\text{k}, R2 = 115\text{k}, R3 = 12.4\text{k}$		62.1		V
Efficiency	$V_{PVIN} = 12\text{V}, V_{LED} = 87\text{V}, I_{LED} = 400\text{mA}$ $V_{PVIN} = 24\text{V}, V_{LED} = 87\text{V}, I_{LED} = 400\text{mA}$ $V_{PVIN} = 48\text{V}, V_{LED} = 87\text{V}, I_{LED} = 400\text{mA}$		92 91 92		% % %
Switching Frequency	$R5 = 31.6\text{k}$		250		kHz
Input Current Limit	$RS3 = 0.015\Omega$		4		A

QUICK START PROCEDURE

It is easy to set up DC1827A to evaluate the performance of the LT3795. Follow the procedure below:

NOTE: PWM must be pulled high to work. If PWM is not used, connect the PWM terminal to a 2V to 5V DC source or connect the PWM pin to V_{REF} on the PCB using R18.

1. Connect a string of LEDs with a forward voltage of 87V or less, but greater than the PV_{IN} voltage, to the LED+ and GND terminals on the PCB as shown in Figure 1.
2. Connect the EN/UVLO terminal to GND.
3. With the power off, connect the input power supply to the PVIN and GND terminals within the voltage range specified on the PCB. Make sure that the input power supply voltage does not exceed the forward voltage of the LED string. OVLO becomes active to inhibit switching for an input voltage greater than 63V.
4. Connect an input to the PWM terminal. If PWM is not used, connect PWM to a 2V to 5V DC source or to V_{REF} on the PCB using resistor R18. PWM must be pulled high to work. For PWM dimming, connect a 100Hz or higher PWM signal to the PWM terminal.
5. Turn the PVIN power supply on.
6. Release the EN/UVLO to GND connection.
7. Observe the LED string running at the programmed LED current; or, observe the reduction of brightness in the LED string with PWM dimming.

QUICK START PROCEDURE

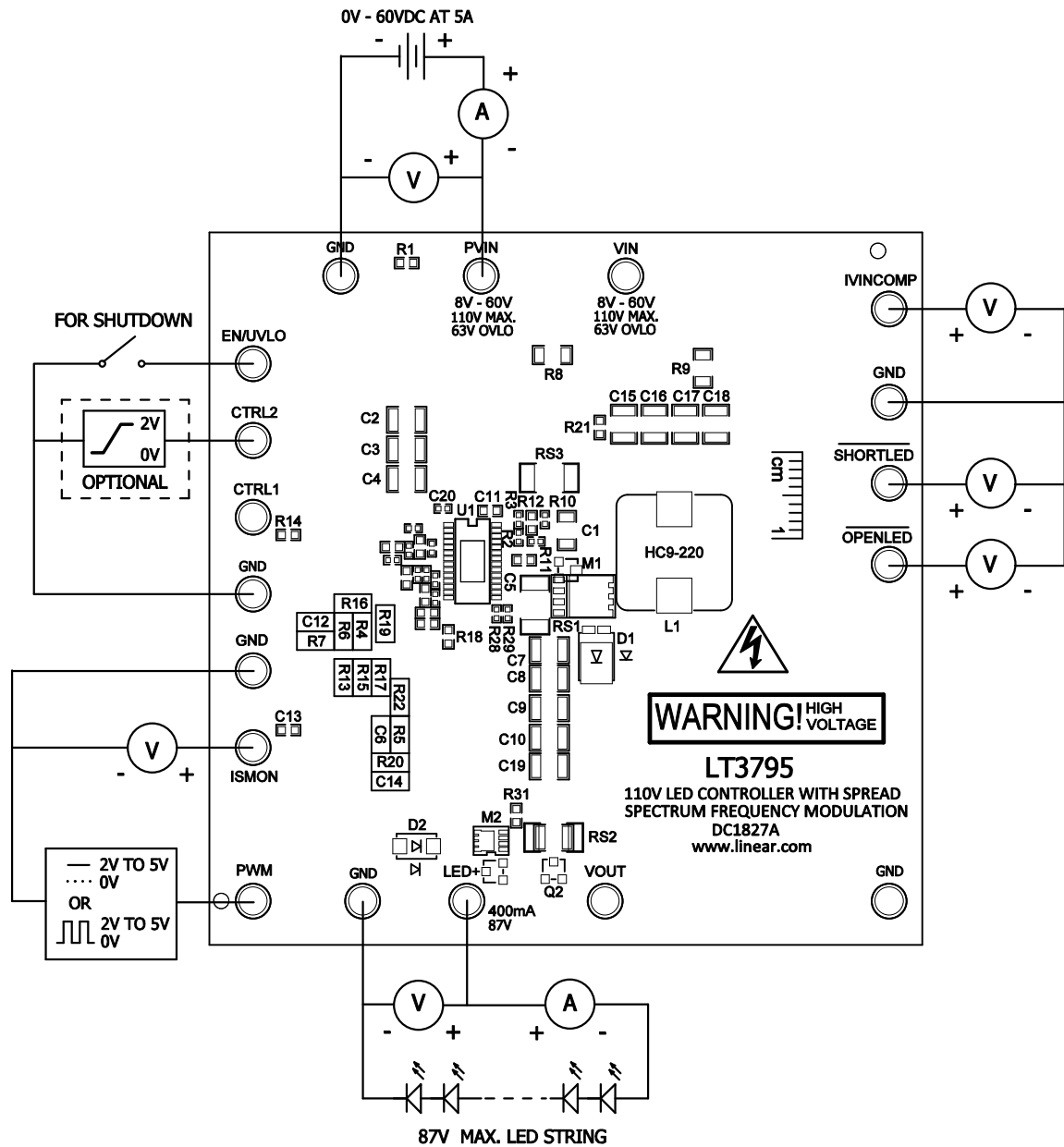

Figure 1. Proper Measurement Equipment Setup for DC1827A

QUICK START PROCEDURE

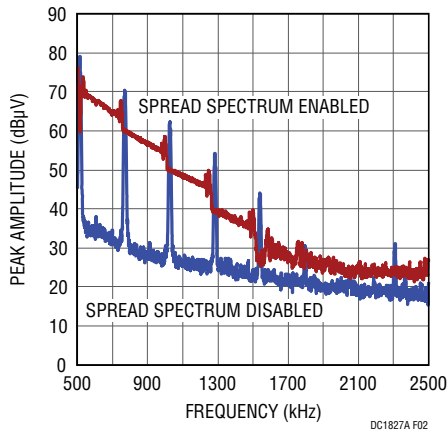

Figure 2. Conducted Peak Emissions with Spread Spectrum Disabled (RAMP Pin Grounded) and the Improvement that Occurs with Spread Spectrum Enabled (6.8nF at RAMP Pin)

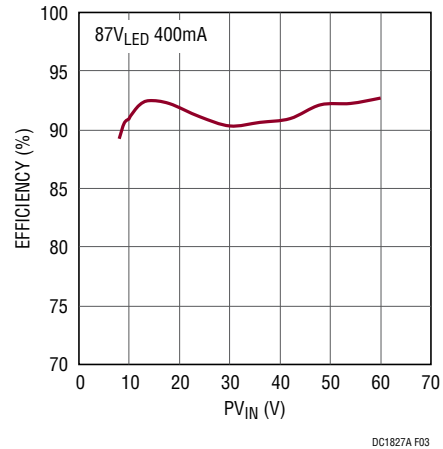

Figure 3. DC1827A Efficiency with 87V_{LED} at 400mA

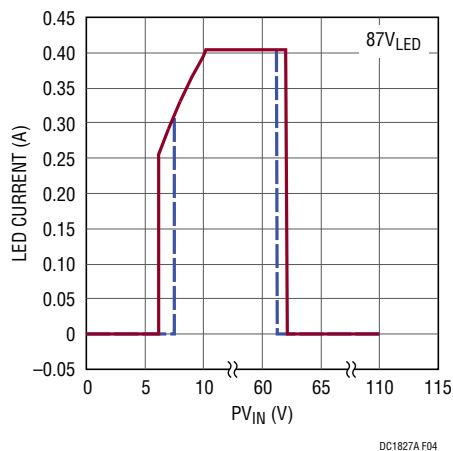

Figure 4. The LED String is 87V. This Output Current vs Input Voltage Graph Shows the Wide Input Voltage Range and the Input Voltages at Which UVLO, Turn-On and OVLO Occur. Input Current Limit Occurs When V_{IN} Is 10V or Less.

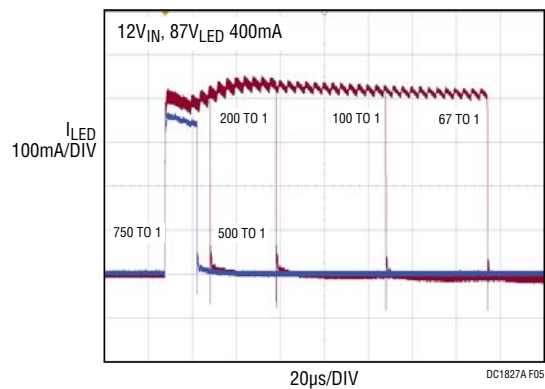

Figure 5. LED Current During PWM Dimming at 100Hz

PARTS LIST

ITEM	QTY	REFERENCE	PART DESCRIPTION	MANUFACTURER/PART NUMBER
Required Circuit Components				
1	1	C1	Cap., X7R 1µF 100V 20% 1206	AVX 12061C105MAT2A
2	7	C2, C3, C4, C7, C8, C9	Cap., X7R 2.2µF 100V 10% 1210	Murata GRM32ER72A225KA35L
		C10		
3	1	C5	Cap., X5R 4.7µF 10V 10% 0603	AVX 0603ZD475KAT2A
4	1	C6	Cap., X7R 0.1µF 25V 10% 0603	AVX 06033C104KAT2A
5	1	C12	Cap., X7R 0.01µF 10V 10% 0603	AVX 0603ZC103KAT1A
6	1	D1	Schottky Diode 5A POWERDI5	Diodes Inc. PDS5100-13
7	1	L1	Inductor, 22µH HC9-SERIES	Cooper Bussmann HC9-220-R
8	1	M1	Mosfet N-Channel, 120V/44A Super SO8	Infineon BSC190N12NS3G
9	1	M2	Mosfet P-Channel, 150V PowerPak 1212-8	Vishay Siliconix Si7115DN-T1-E3
10	1	RS1	Res., LRC 0.015 0.5W 1% 2010	IRC LRC-LR2010LF-01-R015-F
11	1	RS2	Res., LRC 0.620 0.5W 1% 2010	SEI CSRN2010FKR620
12	1	R4	Res., Chip 1.00M 0.06W 1% 0603	NIC NRC06F1004TRF
13	1	R5	Res., Chip 31.6k 0.06W 1% 0402	Vishay CRCW040231K6FKED
14	1	R6	Res., Chip 13.3k 0.06W 1% 0402	Vishay CRCW040213K3FKED
15	1	R7	Res., Chip 10k 0.06W 5% 0402	Vishay CRCW040210K0JNED
16	1	U1	I.C., LED Driver TSSOP28-FE/EB	Linear Tech. Corp. LT3795EFE
Optional Demo Circuit Components				
1	1	C13	Cap., X5R 0.1µF 25V 10% 0603	AVX 06033C104KAT2A
2	1	C11	Cap., X7R 0.01µF 10V 10% 0603	AVX 0603ZC103KAT1A
3	1	C14	Cap., X7R 6.8nF 16V 10% 0603	AVX 0603YC682KAT2A
4	0	C15, C16, C17, C18, C19	Cap., 1210	
5	0	C20	Cap., 0402	
6	0	C21	Cap., 12.5mm Dia.	
7	1	D2	Ultra Fast Rect., 150V/1A SMA	Fairchild Semi. ES1C
8	0	M3	Mosfet N-Channel SOT23	
9	0	Q1,Q2	Trans., PNP SOT23	Zetex FMMT593
10	1	RS3	Res., LRC 0.015 0.5W 1% 2010	IRC LRC-LR2010LF-01-R015-F
11	1	R1	Res., Chip 499k 0.06W 1% 0603	Vishay CRCW0603499KFKEA
12	1	R2	Res., Chip 115k 0.06W 1% 0402	Vishay CRCW0402115KFKED
13	1	R3	Res., Chip 12.4k 0.06W 1% 0402	Vishay CRCW040212K4FKED
14	1	R8	Res./Jumper, Chip 0Ω 1/4W 1A 1206	Vishay CRCW12060000Z0EA
15	0	R9	Res., 1206	
16	0	R10, R15, R19, R22	Res., 0402	
17	1	R11	Res/Jumper, Chip 0Ω 1/16W 1A 0402	Vishay CRCW04020000Z0ED
18	0	R12, R13, R14, R18, R21, R23, R24, R25, R26, R27, R30, R31, R32	Res., 0603	
19	4	R16, R17, R28, R29	Res., Chip 100k 0.06W 5% 0402	Vishay CRCW0402100KJNED
20	1	R20	Res./Jumper, Chip 0Ω 1/16W 1A 0603	Vishay CRCW06030000Z0EA

DEMO MANUAL DC1827A

PARTS LIST

ITEM	QTY	REFERENCE	PART DESCRIPTION	MANUFACTURER/PART NUMBER
Hardware				
1	18	E1, E2, E3, E4, E5, E6, E7, E8, E9, E10, E11, E12, E13, E14, E15, E16, E17, E18	Turret, Testpoint	Mill Max 2501-2-00-80-00-00-07-0

SCHEMATIC DIAGRAM

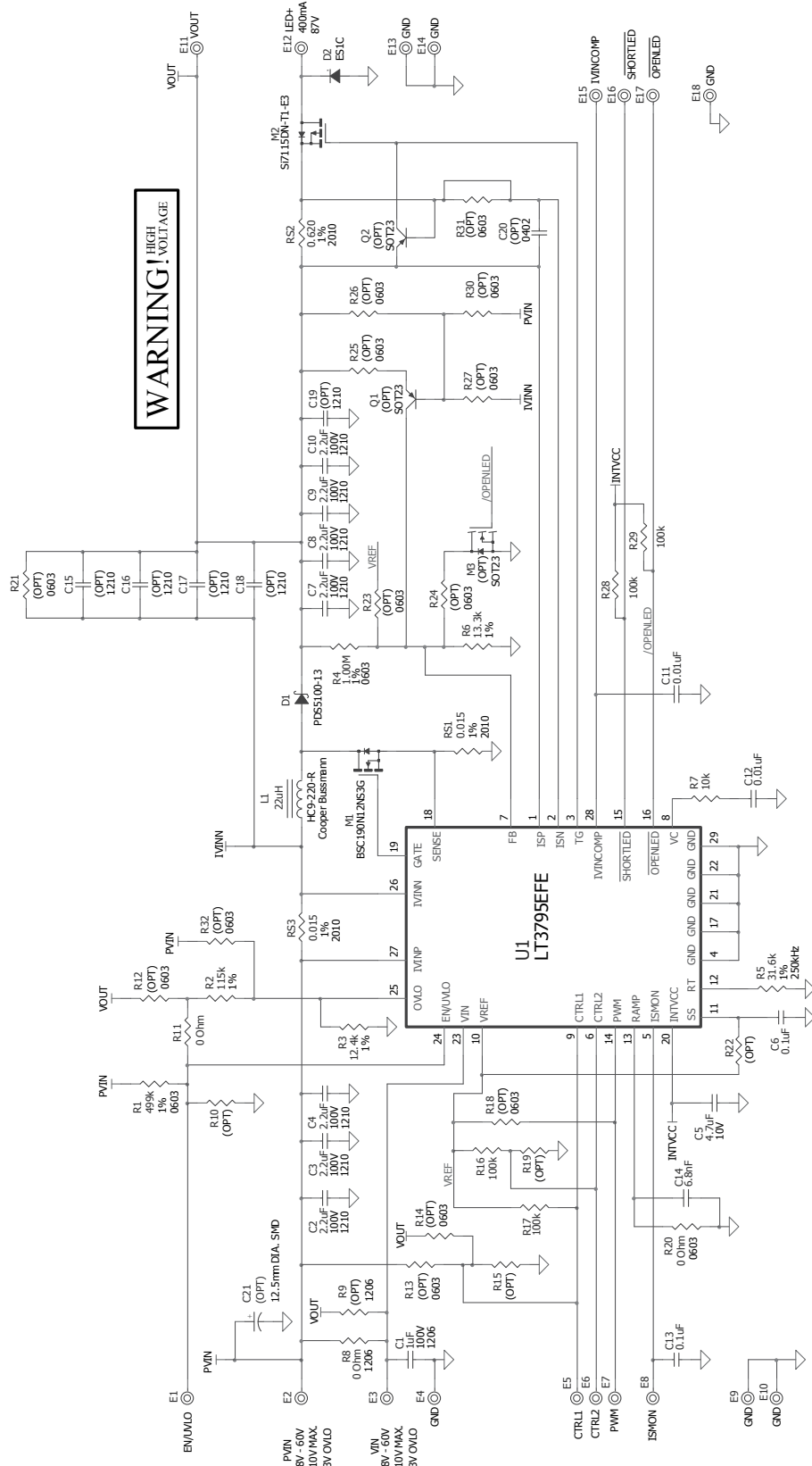



ESD Caution

ESD (electrostatic discharge) sensitive device. Charged devices and circuit boards can discharge without detection. Although this product features patented or proprietary protection circuitry, damage may occur on devices subjected to high energy ESD. Therefore, proper ESD precautions should be taken to avoid performance degradation or loss of functionality.

Legal Terms and Conditions

By using the evaluation board discussed herein (together with any tools, components documentation or support materials, the "Evaluation Board"), you are agreeing to be bound by the terms and conditions set forth below ("Agreement") unless you have purchased the Evaluation Board, in which case the Analog Devices Standard Terms and Conditions of Sale shall govern. Do not use the Evaluation Board until you have read and agreed to the Agreement. Your use of the Evaluation Board shall signify your acceptance of the Agreement. This Agreement is made by and between you ("Customer") and Analog Devices, Inc. ("ADI"), with its principal place of business at One Technology Way, Norwood, MA 02062, USA. Subject to the terms and conditions of the Agreement, ADI hereby grants to Customer a free, limited, personal, temporary, non-exclusive, non-sublicensable, non-transferable license to use the Evaluation Board FOR EVALUATION PURPOSES ONLY. Customer understands and agrees that the Evaluation Board is provided for the sole and exclusive purpose referenced above, and agrees not to use the Evaluation Board for any other purpose. Furthermore, the license granted is expressly made subject to the following additional limitations: Customer shall not (i) rent, lease, display, sell, transfer, assign, sublicense, or distribute the Evaluation Board; and (ii) permit any Third Party to access the Evaluation Board. As used herein, the term "Third Party" includes any entity other than ADI, Customer, their employees, affiliates and in-house consultants. The Evaluation Board is NOT sold to Customer; all rights not expressly granted herein, including ownership of the Evaluation Board, are reserved by ADI. CONFIDENTIALITY. This Agreement and the Evaluation Board shall all be considered the confidential and proprietary information of ADI. Customer may not disclose or transfer any portion of the Evaluation Board to any other party for any reason. Upon discontinuation of use of the Evaluation Board or termination of this Agreement, Customer agrees to promptly return the Evaluation Board to ADI. ADDITIONAL RESTRICTIONS. Customer may not disassemble, decompile or reverse engineer chips on the Evaluation Board. Customer shall inform ADI of any occurred damages or any modifications or alterations it makes to the Evaluation Board, including but not limited to soldering or any other activity that affects the material content of the Evaluation Board. Modifications to the Evaluation Board must comply with applicable law, including but not limited to the RoHS Directive. TERMINATION. ADI may terminate this Agreement at any time upon giving written notice to Customer. Customer agrees to return to ADI the Evaluation Board at that time. LIMITATION OF LIABILITY. THE EVALUATION BOARD PROVIDED HEREUNDER IS PROVIDED "AS IS" AND ADI MAKES NO WARRANTIES OR REPRESENTATIONS OF ANY KIND WITH RESPECT TO IT. ADI SPECIFICALLY DISCLAIMS ANY REPRESENTATIONS, ENDORSEMENTS, GUARANTEES, OR WARRANTIES, EXPRESS OR IMPLIED, RELATED TO THE EVALUATION BOARD INCLUDING, BUT NOT LIMITED TO, THE IMPLIED WARRANTY OF MERCHANTABILITY, TITLE, FITNESS FOR A PARTICULAR PURPOSE OR NON-INFRINGEMENT OF INTELLECTUAL PROPERTY RIGHTS. IN NO EVENT WILL ADI AND ITS LICENSORS BE LIABLE FOR ANY INCIDENTAL, SPECIAL, INDIRECT, OR CONSEQUENTIAL DAMAGES RESULTING FROM CUSTOMER'S POSSESSION OR USE OF THE EVALUATION BOARD, INCLUDING BUT NOT LIMITED TO LOST PROFITS, DELAY COSTS, LABOR COSTS OR LOSS OF GOODWILL. ADI'S TOTAL LIABILITY FROM ANY AND ALL CAUSES SHALL BE LIMITED TO THE AMOUNT OF ONE HUNDRED US DOLLARS (\$100.00). EXPORT. Customer agrees that it will not directly or indirectly export the Evaluation Board to another country, and that it will comply with all applicable United States federal laws and regulations relating to exports. GOVERNING LAW. This Agreement shall be governed by and construed in accordance with the substantive laws of the Commonwealth of Massachusetts (excluding conflict of law rules). Any legal action regarding this Agreement will be heard in the state or federal courts having jurisdiction in Suffolk County, Massachusetts, and Customer hereby submits to the personal jurisdiction and venue of such courts. The United Nations Convention on Contracts for the International Sale of Goods shall not apply to this Agreement and is expressly disclaimed.