

UNCONTROLLED DOCUMENT

| | | |
|------------------|-------------------------------------|----------|
| PART NUMBER | | REV. |
| SSL-LX5093XSGC/B | | B |
| REV. | E.C.N. NUMBER AND REVISION COMMENTS | DATE |
| A | E.C.N. #10BRDR. & REDRAWN IN 3D. | 5.18.01 |
| B | E.C.N. #11148 | 10.30.06 |

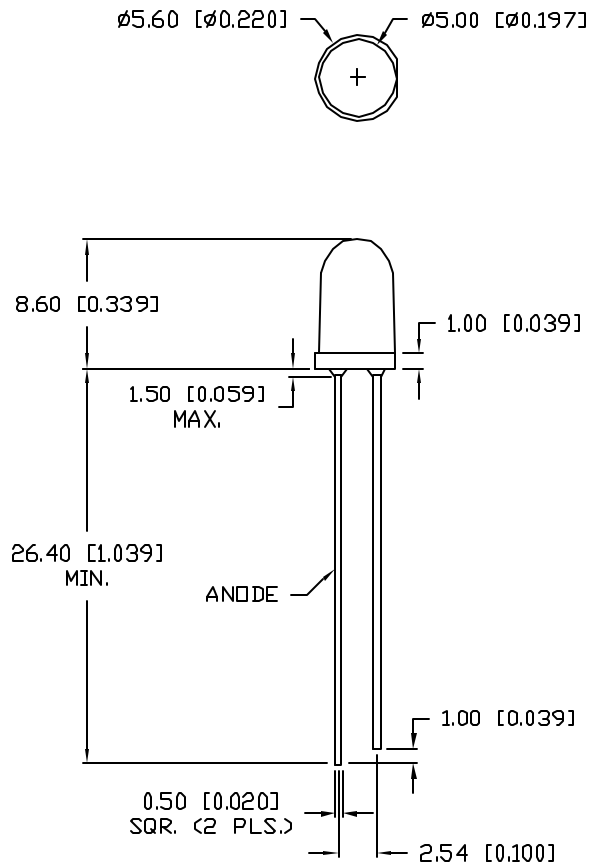

ELECTRO-OPTICAL CHARACTERISTICS $T_A=25^{\circ}\text{C}$ $I_f=20\text{mA}$

| PARAMETER | MIN | TYP | MAX | UNITS | TEST COND |
|--------------------|-------------|-----|-----|----------|----------------------|
| PEAK WAVELENGTH | | 565 | | nm | |
| FORWARD VOLTAGE | | 2.2 | 2.6 | V_f | |
| REVERSE VOLTAGE | 5.0 | | | V_r | $I_f=100\mu\text{A}$ |
| AXIAL INTENSITY | | 600 | | med | $I_f=20\text{mA}$ |
| VIEWING ANGLE | | 10 | | 2x theta | |
| EMITTED COLOR: | GREEN | | | | |
| EPOXY LENS FINISH: | WATER CLEAR | | | | |

LIMITS OF SAFE OPERATION AT 25°C

| PARAMETER | MAX | UNITS |
|--------------------------|------------|------------|
| PEAK FORWARD CURRENT* | 100 | mA |
| STEADY CURRENT | 30 | mA |
| POWER DISSIPATION | 98 | mW |
| DERATE FROM 25°C | -1.2 | mW/°C |
| OPERATING, STORAGE TEMP. | -40 TO +85 | °C |
| SOLDERING TEMP. | +260 | °C |
| 2.0mm FROM BODY | | 3 SEC. MAX |

* $t < 10\mu\text{s}$



*UNLESS OTHERWISE SPECIFIED TOLERANCES PER DECIMAL PRECISION ARE: X=±1 (±0.039), X.X=±0.5 (±0.020), X.XX=±0.25 (±0.010), X.XXX=±0.127 (±0.005). LEAD SIZE=±0.05 (±0.002), LEAD LENGTH=±0.75 (±0.030), MIN.=^{+0.00}/_{-0.00} MAX.=^{+0.00}/_{-0.00}

UNCONTROLLED DOCUMENT

| | |
|------|------------------|
| REV. | PART NUMBER |
| B | SSL-LX5093XSGC/B |

CONFIDENTIAL INFORMATION
 THE INFORMATION CONTAINED IN THIS DOCUMENT IS THE PROPERTY OF LUMEX INC. EXCEPT AS SPECIFICALLY AUTHORIZED IN WRITING BY LUMEX INC, THE HOLDER OF THIS DOCUMENT SHALL KEEP ALL INFORMATION CONTAINED HEREIN CONFIDENTIAL AND SHALL PROTECT SAME IN WHOLE OR IN PART FROM DISCLOSURE AND DISSEMINATION TO ALL THIRD PARTIES.



290 E. HELEN ROAD
 PALATINE, IL 60067-6976
 PHONE: +1.847.359.2790
 US WEB: www.lumex.com
 TW WEB: www.lumex.com.tw

T-5mm (T-1 3/4) 565nm SUPER GREEN LED,
 WATER CLEAR TAPERED LENS.

RELIABILITY NOTE
 OUR MANY YEARS OF EXPERIENCE DATA ACCUMULATION INDICATE THAT SOLDER HEAT IS A MAJOR CAUSE OF EARLY AND FUTURE FAILURE. PLEASE PAY ATTENTION TO YOUR SOLDERING PROCESS.

| | | | |
|-----------|-------------|--------------|----------------|
| DRAWN BY: | CHECKED BY: | APPROVED BY: | DATE: 10.30.06 |
| JC | | | PAGE: 1 OF 1 |
| | | | SCALE: N/A |